



SHADOWPLY INFORMATION GUIDE

INTERIORS RANGE

SEPTEMBER 2018



SHADOWPLY Classic SMOOTH	SHADOWPLY + Classic SMOOTH
SHADOWPLY Classic TEXTURE	SHADOWPLY + Classic TEXTURE
SHADOWPLY U-Groove SMOOTH	SHADOWPLY + U-Groove SMOOTH
SHADOWPLY U-Groove TEXTURE	SHADOWPLY + U-Groove TEXTURE
SHADOWPLY V-Groove SMOOTH	SHADOWPLY + V-Groove SMOOTH
SHADOWPLY V-Groove TEXTURE	SHADOWPLY + V-Groove TEXTURE

I.0 INTERIOR PLYWOOD RANGE

Manufactured by Carter Holt Harvey and sold in Australia by CHH Plywood Pty Limited (CHH Plywood), the Shadowply portfolio is a range of untreated plywood panels suitable for internal use as wall and ceiling linings. The Shadowply range of plywood panels consists of natural, untreated panels available in a smooth or textured face with the option of two different grooved profiles, depending on the visual finish that is desired.

2.0 PRODUCT INFORMATION









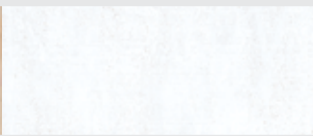

2.1 PRODUCT DESCRIPTIONS & RANGE

Shadowply interior panels are manufactured from radiata pine wood veneers. The veneers are placed at right angles to each other for maximum strength and stability then bonded together with synthetic phenolic (PF) resin to form a strong and permanent Type A bond.

Shadowply panels are available in a Textured (bandsawn) or smooth face appearance with a Classic or Grooved profile. (refer Table 1 for surface finishes). The plywood panels are available pre-primed

or uncoated and suitable for painting, staining or clear coating as applicable. Refer to Table 2 for the Shadowply range size and profiles.

For plywood used as an exterior cladding, refer to the current Shadowclad Specification & Installation Guides which can be downloaded from www.shadowclad.com.au.

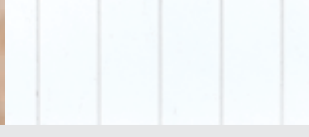
Table 1		Surface Finishes			
Classic					
Texture	Texture Plus	Smooth	Smooth Plus		
					
U-Groove					
Texture	Texture Plus	Smooth	Smooth Plus		
					
V-Groove					
Texture	Texture Plus	Smooth	Smooth Plus		
					

Important Notice & Warning

While the products in this document possess the characteristics described, no representation is made that the products will be effective in all locations and circumstances. Much depends upon building design, construction practices and the environment in which the products are used. Statements about the attributes and performance characteristics of the products are made on the assumption that the products are properly stored, handled, installed, used and maintained in their relevant application.

You should not rely solely on this document when using the products. CHH Plywood recommends obtaining professional building advice which takes into account your particular circumstances and site conditions. CHH Plywood is not involved in, and does not assume responsibility for, the selection, installation or maintenance of our products in situ.

Failure to install CHH Plywood in accordance with applicable building regulation requirements and instructions may lead to personal injury, loss or damage, and may adversely affect the performance of the products.

Table 2

Shadowply Product Range

	Classic Smooth	Classic Texture	U-Groove	V-Groove
Surface Finish	Smooth	Textured	Smooth or Textured	Smooth or Textured
Sheet Length	2400 and 2700mm	2440 and 2745mm	2440 and 2745mm	2400 and 2700mm
Width (Overall)	1200mm	1216mm	1216mm	1200mm
Width (Effective)	1200mm	1200mm	1200mm	1200mm
Cover/Width Tolerance	+/- 1mm	+/- 1mm	+/- 1mm	+/- 1mm
Nominal Thickness	12mm	12mm	12mm	12mm
Weights (kg/m²)	6.6	6.6	6.6	6.6
R-Value (m² °C/W)	0.104	0.104	0.104	0.104
Groove Profile	N/A	N/A	9mm wide, 5mm deep at 150mm centres	4mm wide, 2mm deep at 100mm centres
Edge Profile	Square Edge	Ship Lap	Ship Lap	Tongue and Groove
Treatment Available	Untreated	Untreated	Untreated	Untreated
Proposed Use	Internal dry applications	Internal dry applications	Internal dry applications	Internal dry applications

Shadowply Ship Lap Profiles and Dimensions

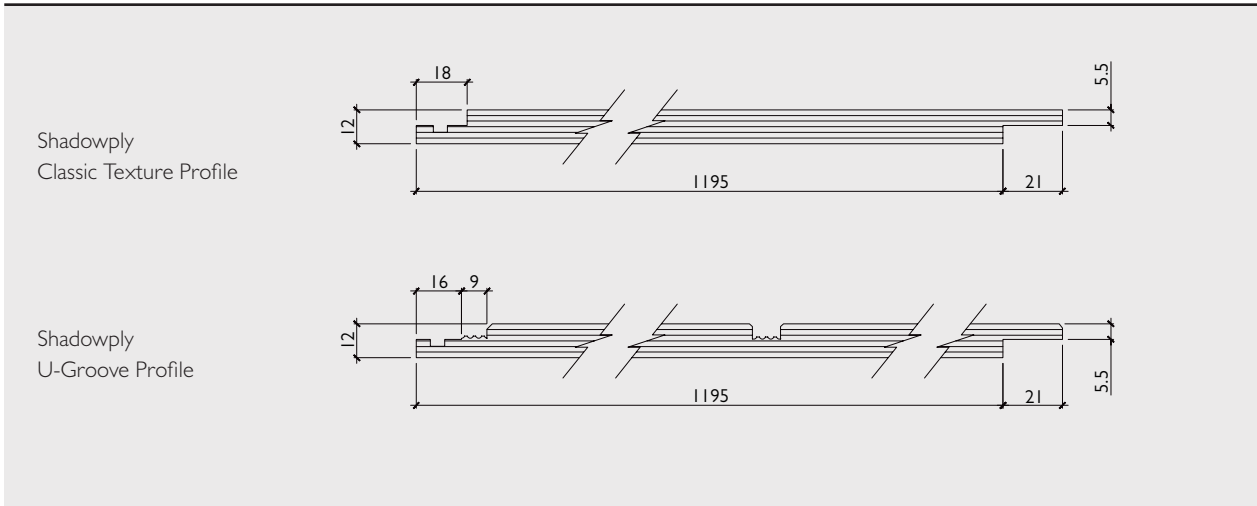

Shadowply U Groove and V Groove Profiles and Dimensions

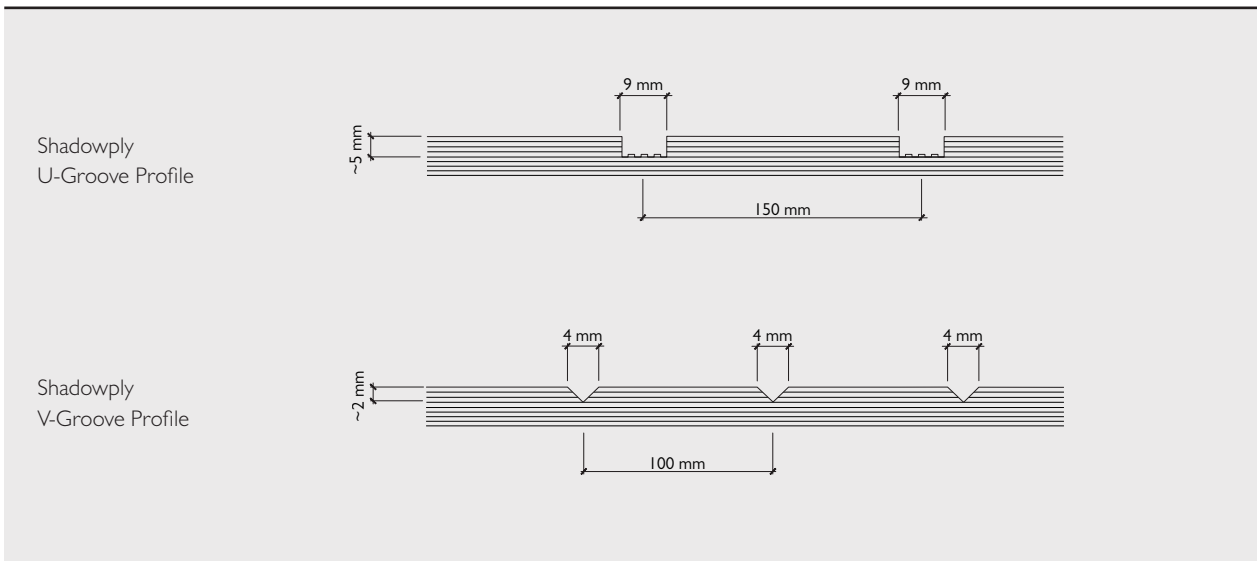

2.2 SUITABLE APPLICATIONS

Shadowply plywood is suitable for internal, dry applications where the use of untreated plywood is permitted. Wet areas such as bathrooms, laundries and kitchens are subject to specific design and as such beyond the scope of the literature.

Applications Include:

- Interior wall and ceiling linings.
- Feature walls and partitions.
- Back lining to exposed rafters.
- Commercial interiors and shop fitouts.
- Furniture and cabinets.

Advantages

- Decorative real wood panelling.
- Tough and impact resistant.
- Strong, providing stiffness and rigidity.
- Only requires standard carpentry tools.
- Lightweight, easy to work and finish.
- Ability to create slight curves.
- Water resistant glue bond.

2.3 SHADOWPLY PLUS

Shadowply Plus features a factory applied grade performance coating suitable for use with most paint and film forming stain systems. Using a unique powder coating process on the panel face and edges means Shadowply Plus panels can be immediately top coated on site, eliminating (in most cases) the need for expensive and time consuming wet primers.

CHH Plywood recommends the use of Shadowply Plus where suitable paint or film forming stains are being used.

Shadowply Plus features:

- High 60-80 microns film build white coating, can be up to 2-3 times thicker than traditional wet primers.
- Continuous powder coated surface forms an effective moisture barrier for a drier more consistent painting surface.
- Saves time and money as traditional wet primers are not normally required.
- Low volatile organic compound (VOC) coating.
- Once installed Shadowply Plus should be top coated, to coating manufacturer's recommendations.

2.4 SUSTAINABILITY

Shadowply plywood is manufactured from radiata pine. It is grown on tree farms which are tended and harvested to provide wood for plywood manufacture. The crop is managed on a sustainable basis to yield millable trees. New Zealand plantations are managed

in compliance with the New Zealand Forest Accord. Shadowply plywood range is manufactured in New Zealand at CHH Plywood Tokoroa mill. Available Forestry Stewardship Council (FSC) (SCS-COC-001316) certified upon request.

2.5 PRODUCT IDENTIFICATION

Every sheet of Shadowply plywood is branded in accordance with AS/NZS 2269 Plywood - Structural. The Shadowply interior plywood panels are also branded as UNTREATED - FOR INTERNAL USE ONLY.

Untreated Example:

SHADOWPLY STRUCTURAL A BOND E0
AS/NZS 2269.0:2012
UNTREATED – FOR INTERNAL USE
ONLY PAT 01/12/15 12:23:45



Shadowply |
Interiors |



SHADOWPLY PRODUCT INFORMATION

See important notice and warning on page 2.

SHADOWPLY | 1800 338 463 | www.shadowply.com.au

3.0 DESIGN CONSIDERATIONS

3.1 DESIGN RESPONSIBILITY

Design responsibility lies with the building owner and the professionals that they engage. The specifier for the project must ensure that the details in the specification for their individual projects are appropriate for the intended application. The specifier must also ensure that additional detailing is provided for specific

design or any areas that fall outside the scope and specifications of this literature.

Good detailing which avoids moisture or dust accumulation on the sheet surface can help increase durability and aesthetics.

3.2 PRODUCT SCOPE

The information and details within this guide are for the use of untreated plywood panels used in dry internal spaces for wall and ceiling linings. Wet areas such as bathrooms, laundries and kitchens

are subject to specific design and as such beyond the scope of this literature.

3.4 HEALTH & SAFETY

Untreated plywood must be installed and used as per the Safety Data Sheet (SDS) which can be downloaded from www.shadowply.com.au.

Always wear safety glasses or non-fogging goggles when cutting plywood panels.

If wood dust exposures are not controlled when machining (sawing, routing, planing, drilling etc.) a class P1 or P2 replaceable filter or disposable face piece respirator should be worn. Wear comfortable work gloves to avoid skin irritation and the risk of splinters. Wash hands with mild soap and water after handling panels.

3.5 STORAGE & HANDLING

Interior Plywood Panels must be:

- Kept dry, stored under cover.
- Handled and stacked with care to avoid damage.
- Stacked flat; clear of the ground, on at least three evenly spaced bearers.
- Stored in well-ventilated areas away from sources of heat, flames or sparks.
- To minimise dimension movements, allow panel to equilibrate in the final environmental conditions before installation.

3.6 INTERNAL LINING

Internal Wall Linings & Ceilings

- Skirtings, dado mouldings, furniture trim, bookshelves, cornices and other trim can be used to hide mechanical fasteners.
- Deep skirting and cornices can be used to extend the effective length of shorter sheets in longer applications.
- Unsupported plywood sheets may distort with environmental changes or when coated, particularly if the coating is applied to one side only. Where on going sheet flatness is critical, plywood sheets must be supported by framing.

4.0 INSTALLATION

4.1 PRE INSTALLATION INSPECTION

- Refer to section 3.5 for Storage & Handling information.
- Prior to installation, inspect panels for visual defects. Responsibility lies with the installer to ensure individual panels meet the aesthetic requirements of the specific project. CHH Plywood will not be responsible for installation or removal costs where aesthetically unacceptable panels have been installed.

4.2 SHEET LAYOUT

- Maximum framing centres are shown in table 3 below.
- Avoid single spans between framing supports.
- For all square edge and shiplap sheets, products must be supported at sheet edges.
- Products with a tongue & groove edge profile do not need support unless specified.
- Closer spacings are recommended for high impact areas.

Table 3: Maximum Frame Spacings

Application	Sheet Orientation	Maximum frame centres (mm)
Internal Walls	Fixed vertically, max stud spacing without nogs or dwangs	600
Internal Walls	Fixed horizontally, maximum stud facing	600
Internal Ceilings	Face grain across framing, under or over frame	600

Note: Unsupported plywood sheets may distort with seasonal changes or when coated particularly if the coating is applied to one side only. Where on going sheet flatness is critical plywood sheets must be supported by framing.

4.3 FASTENING & FIXING

- Where there is risk of panel size change due to changes in moisture levels allow a 2 to 3 mm expansion gap between sheets
- Where nailing or screwing use only flathead nails or screws, with or without construction adhesives
- Fasteners must be at least 3 fastener diameters or 7 mm from the edge of the sheet
- For tongue and groove products fasten 15 mm from tongue and groove edges

General fixing techniques include:

- Nailing (including panel pins) pins/brads, screw and gluing.
- Use of scotia/dado & skirting to hide joints and fixings.
- Battens and rafters to hide joints.
- Creating design features of mechanical fasteners (such as use of rosehead fasteners).
- Negative detailing between panel edges.

Standard fixing pattern: unless otherwise specified fasten edges and ends of sheets at 150 cm centres, and within the panel at no more than 300 mm centres. Do not overdrive power driven nails.

Shadowply Panels can be installed by using a variety of fastening and fixing methods depending on the degree of fastener concealment desired.

Fixing for Internal Non Bracing Walls & Ceilings:

Nails: Use 40mm panel pins/brads 150mm centres at sheet edges and 300mm centres on intermediate supports. Daubs of a polyurethane based adhesive at 300mm centres is recommended on all framing members.

Where back nailing over rafters use galvanised flat head nails 40 x 2.5mm.

Screws: Use 8g x 40mm screws and adhesive as per nail specifications.

Adhesives Only (Not Suitable for Ceiling Applications)

Panels may be fixed with a bead of MS polymer based adhesive on all frame supports through the application of Ø 7mm continuous beads. Sheets must be supported by applying pressure during the adhesive curing process in accordance with the adhesive manufacturer specifications or with mechanical fasteners such as nails, panel pins/brads or screws at 300mm centres on all supporting framing.

4.4 SHIP LAP VERTICAL JOINTS

SP01: Shadowply Ship Lap Classic Texture Vertical Joints

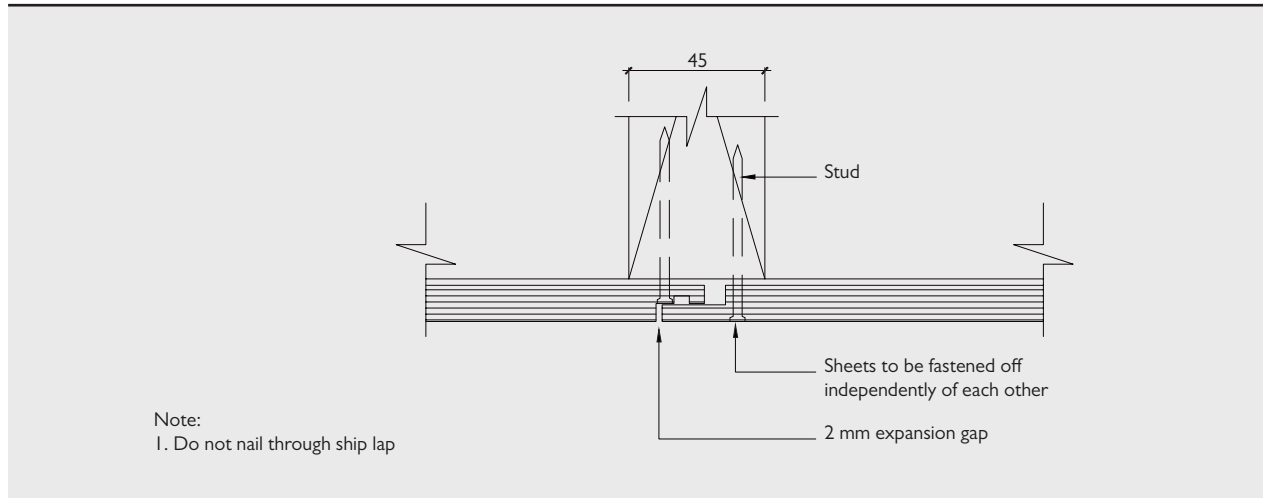

SP02: Shadowply Ship Lap U-Groove Vertical Joints

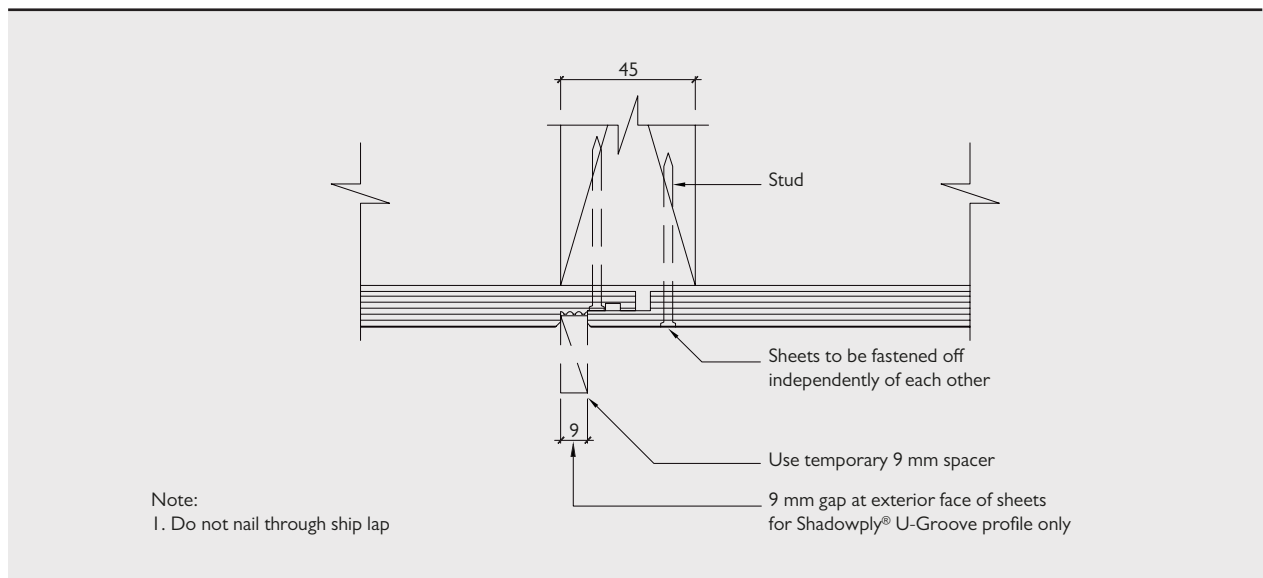

4.5 FORMING CURVES

- Shadowply panels can be curved for applications such as ceilings and feature walls. Table 5 provides guidance for the minimum recommended radii.
- Shaped top and bottom plates or noggs can be jigsaw cut from 17, 19, 21 or 25mm thick Ecoply®.
- Fix covering plywood over the framework.
- Attach the out edges with tack nails or clamps first to develop the curve and then fix sheets from the centre out.
- For load bearing curves check capability using a structural designer.
- Use recommended fastener size as detailed in Table 4 at 150mm centres on all frames. Longer fasteners, ring shank or annular grooved nails will provide improved resistance to tension. Adhesives alone are not normally recommended in tension applications.

4.6 FINISHING

Punch nails before finishing and apply a first coat (clear, primer or sealer) before filling punched holes to minimise dryout or staining. High quality paints, stains or clear finishes are recommended for Shadowply plywood. Tinted clear finishes can provide a full range of architectural options that show the warmth of wood while reducing yellowing and other ultraviolet effects. The use of high gloss finishes and paints tend to highlight naturally occurring and manufacturing characteristics of plywood such as change in grain and beat marks from the sanding.

Matt finishes and paints are recommended to provide a natural timber finish.

Shadowply panels are wood based and respond to changes in humidity. Avoid using inflexible coatings (such as epoxies) that may check on movement of the wood. For ceilings or similar applications it is an advantage to prefinish panels prior to installation. Always refer to the coating manufacturer's specifications for best practice.

Table 4: Fasteners Shadowply

Minimum nail size in timber framing	60 x 2.8mm
Screw size in timber framing	8g x 40mm
1.15mm steel framing¹	10-24-404
Screw size in 2.80mm steel framing¹	10-16-404

¹ Self taping, self counter-sinking screw

Table 5: Bending Radii for Shadowply Products

Recommended minimum bending radii for Shadowply products	
Along face (m)	3.6
Across face (m)	2.4

Face Checking

Face checks are lengthwise separations of wood fibres in the face veneer of the plywood. They result from the normal swelling and shrinking of wood as it gains and loses moisture which is exacerbated by darker colours. This will be more pronounced where sheets are exposed to direct sunlight compared with more shade areas inside the building. It is important to realise that these checks are superficial, being confined to the face veneer. They do not alter the structural integrity of the plywood in any way. If you are the specifier, it is important to discuss these issues with your client before finalising colour choice. If checking occurs, repaint with a good quality, 100% acrylic paint suitable for internal applications in accordance with the manufacturer's instructions, thoroughly working paint into the face checks with a paint brush.

Clear Coatings & Uncoated Shadowply

If Shadowply is left uncoated or is clear coated in high sun exposure areas of the building the long term aesthetics of the board may be reduced.

5.0 COATING & APPLICATION

5.1 SURFACE PREPARATION

Refer to section 3.5 Storage and Handling. Shadowply plywood is manufactured and stored in dry conditions at CHH Plywood

manufacturing facilities. It is the applicator's responsibility to ensure the surface is dry and free from dust and mould prior to coating.

5.2 COATING APPLICATION

Coatings for Shadowply texture products should be applied by brush to ensure adequate coating film build is achieved, whilst coatings for Shadowply Smooth sheets may be applied using a roller or brush ensuring adequate film build up. For detailed advice

on surface preparation, coating, product suitability and general coating practice always refer to the coating manufacturer prior to application.

5.3 COATING SELECTION

The selection, application and maintenance of coatings is the responsibility of building owners and the professionals that they engage. For advice on specific coating products and their suitability for use on plywood always refer to the coating manufacturer's specifications.

The following coating information should be treated as a generic guide to coating systems typically used with Shadowply interior lining products.

It is important to note regardless of the internal lining selected there will always be a level of coating maintenance required to ensure the lining material is sufficiently coated and maintains the desired appearance.

Paints & Film Forming Stains

Three coats (1 undercoat, 2 top coats) of a good quality, 100% acrylic paint system with a light reflectance value (LRV) of 50% or greater (i.e. light colours) which is regularly maintained will provide the highest level of protection and durability for Shadowply and is likely to require the least amount of coating maintenance over the life of the interior lining.

Dark colours (LRV of below 50%) may still be used, however they are likely to increase heat and stress on the panel surface, reducing the panels overall lifespan and increasing the level of coating maintenance required to maintain an acceptable visual appearance.

Some film forming stains (i.e. coatings with the consistency of paint but with an appearance similar to penetrating stains) may offer similar protection qualities to paints however advice and assurance should be sought from the coating manufacturer as to their suitability for use with Shadowply prior to application. Where paints or film forming stains are to be used, Shadowply Plus is recommended. Shadowply Plus features a factory applied performance coating which in most cases eliminates the use of time consuming wet primers. Shadowply Natural can also be used with paint however a conventional wet primer is required as part of the coating manufacturers overall system specification.

Penetrating Stains

Penetrating stains show the natural texture and character of timber and are widely used on Shadowply. Due to their translucency, penetrating stains are likely to require additional coating maintenance during the panel's life to maintain an acceptable visual appearance. Penetrating stains should only be used on Shadowply Natural and are not recommended for use on Shadowply Plus. CHH Plywood does not recommend the use of linseed oil based coating which have the potential to promote mould growth in this product.

6.0 LIMITATIONS

The information contained in this document is current as at September 2018 and is based on data available to CHH Plywood at the time of going to print.

All photographic images are intended to provide a general impression only and should not be relied upon as an accurate example of Shadowply plywood products installed in accordance with this document.

This publication replaces all previous CHH Plywood design information and literature relating to plywood suitable for use in interior applications. CHH Plywood reserves the right to change the information contained in this document without prior notice.

It is your responsibility to ensure that you have the most up to date information available, including at the time of applying for a building consent. You can call toll free on 1800 338 463 or visit www.shadowply.com.au to obtain current information.

CHH Plywood has used all reasonable endeavours to ensure the accuracy and reliability of the information contained in this document. However, to the maximum extent permitted by law, Shadowply assumes no responsibility or liability for any inaccuracies, CHH Plywood or errors in this information nor for any actions taken in reliance on this information.



Contemporary |
Plywood Solutions

shadowply

Phone: 1800 338 463
www.shadowply.com.au

September 2018

